

Atlas outdoor

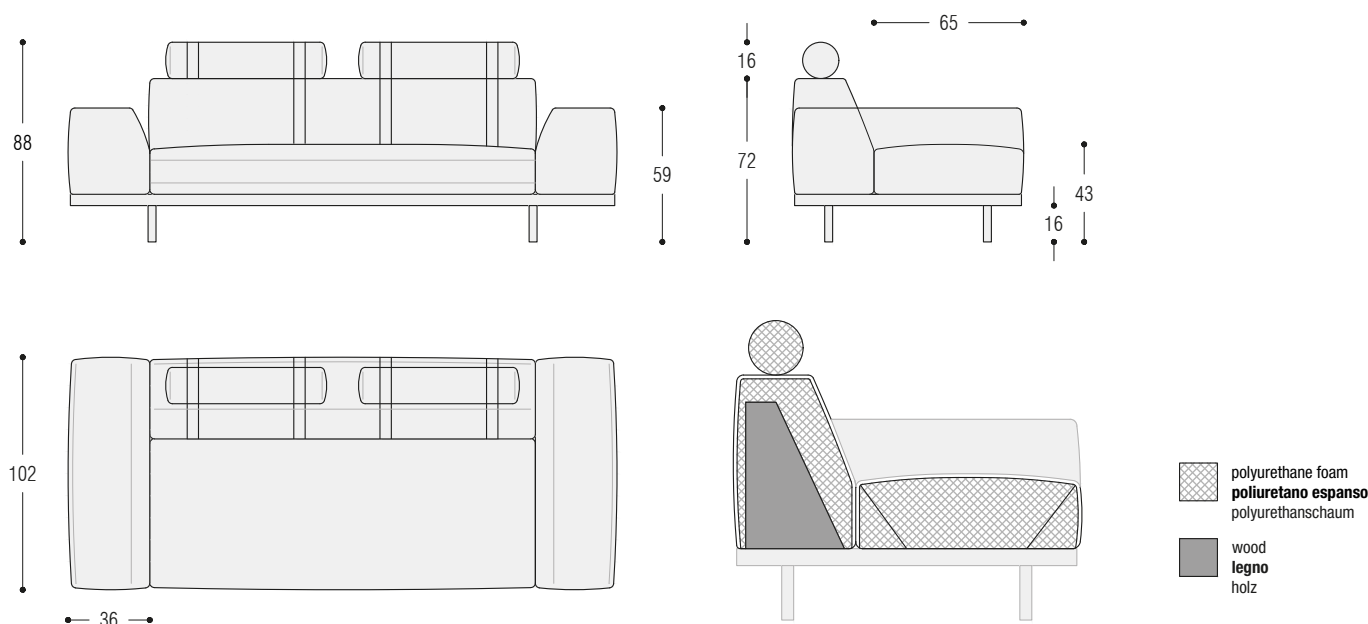

TECNICAL FEATURES

Structure: base in painted aluminum. Backrests and armrests in multi-ply wood.

Padding: non-deformable polyurethane foam of various densities covered with waterproof material.

Feet: in painted aluminum.

Covers: completely removable with "Flat" stitching.

Headrests: in polyurethane foam covered with waterproof material. Placement on the backrest is via a rope-colored polyester strap, fixed at the bottom with Velcro.

Tray: in Iroko wood.

Metal accessories: all the metal elements such as fixing hooks for backrests and armrests, screws, staples and more are in stainless steel.

Important notes: the components of this element are tested to withstand both direct sunlight and rain. However, it is recommended to use it in sheltered areas such as covered verandas or terraces. However, it is recommended to cover it properly or bring it indoors during the winter season or when not in use, to protect it from dirt and ensure greater durability.

CARATTERISTICHE TECNICHE

Struttura: basamento in alluminio verniciato. Schienali e braccioli in legno multistrato.

Imbottitura: in poliuretano espanso indeformabile a densità differenziata rivestito in materiale impermeabile.

Piedini: in alluminio verniciato.

Rivestimento: completamente sfoderabile con cuciture "Piatte".

Poggiatesta: in poliuretano espanso rivestito in materiale impermeabile. Il posizionamento sullo schienale avviene tramite un nastro in poliestere colore corda, fissato sul fondo con del Velcro.

Vassoio: in legno di iroko.

Accessori in metallo: tutti gli elementi in metallo quali ganci di fissaggio per gli schienali e i braccioli, viti, graffe e altro sono in acciaio inox.

Note importanti: i componenti di questo elemento sono testati per resistere sia alla luce diretta del sole quanto alla pioggia. Tuttavia si consiglia di coprirlo adeguatamente o di portarlo all'interno nei mesi invernali o se non utilizzato, per proteggerlo dallo sporco e garantirne una durata maggiore.

TECHNISCHE DATEN

Struktur: Sockel aus lackiertem Aluminium. Rückenlehnen und Armlehnen aus mehrschichtigem Holz.

Polsterung: formstabilem Polyurethanschaum verschiedener Härtegrade, bezogen mit wasserdichtem Material.

Füße: aus lackiertes Aluminium.

Bezug: komplett abziehbar mit „Flache“ Nähten.

Kopfstützen: aus Polyurethanschaum, bezogen mit wasserdichtem Material. Die Positionierung auf der Rückenlehne erfolgt über einen seilfarbenen Polyesterband, das am unteren Ende mit Klettverschluss befestigt ist.

Tablett: aus Iroko-Holz.

Metallzubehör: alle Metallelemente wie Befestigungshaken für Rücken- und Armlehnen, Schrauben, Klammern etc. sind aus Edelstahl.

Wichtige Hinweise: Die Bestandteile dieses Möbelteils sind auf ihre Widerstandsfähigkeit gegen direkte Sonneneinstrahlung und Regen getestet. Es wird jedoch empfohlen, es in den Wintermonaten oder bei Nichtgebrauch angemessen abzudecken oder an einem geschützten Ort unterzustellen, um es vor Schmutz zu schützen und eine längere Lebensdauer zu gewährleisten.

Atlas outdoor

Sofa cm 180 without headrest

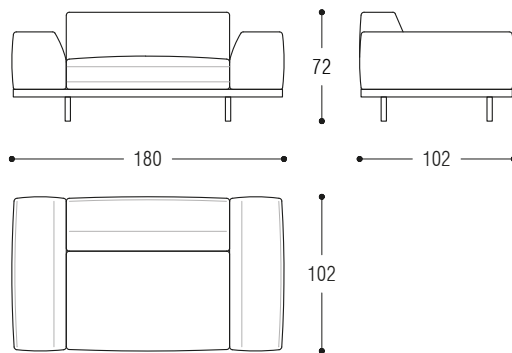

Sofa cm 240 without headrest

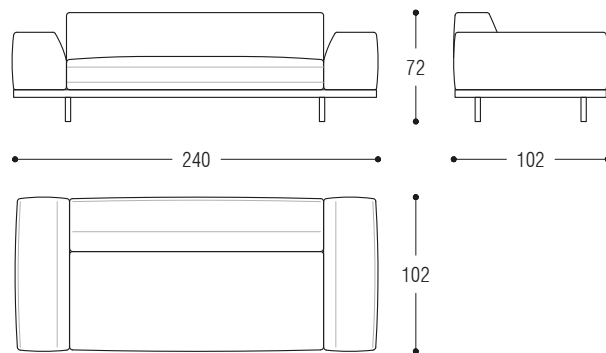

Element cm 180 left (also available right) without headrest

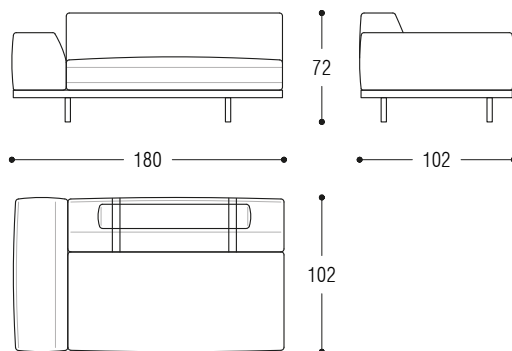

Atlas outdoor

Element cm 180 right (also available left) without headrest

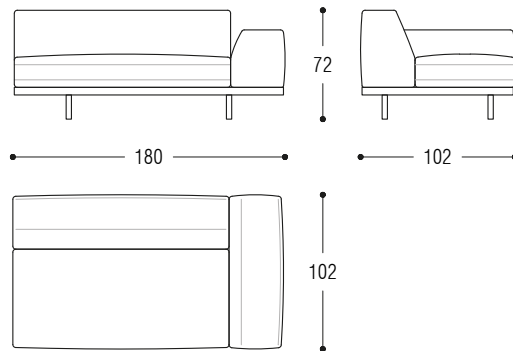

Element cm 240 left (also available right) without headrest

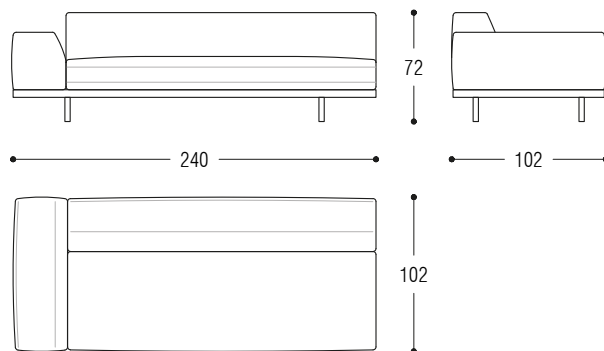

Element cm 240 right (also available left) without headrest

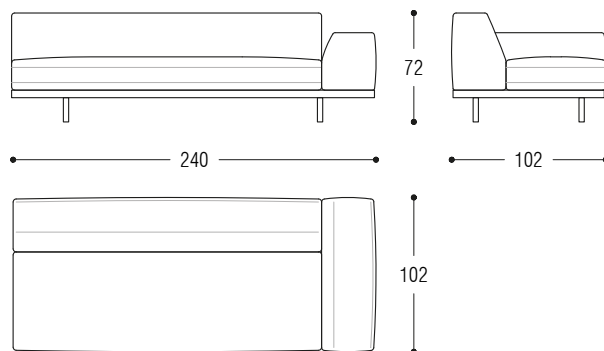

Atlas outdoor

Endunit cm 180x100 without headrest

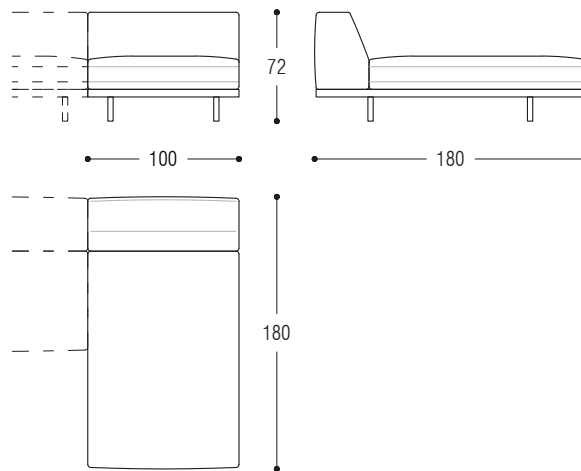

Sunbed cm 180x100 without headrest

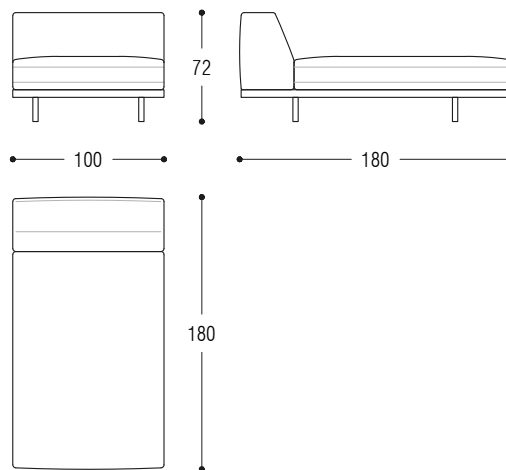

Bench cm 240 for right tray (also available left) without headrests

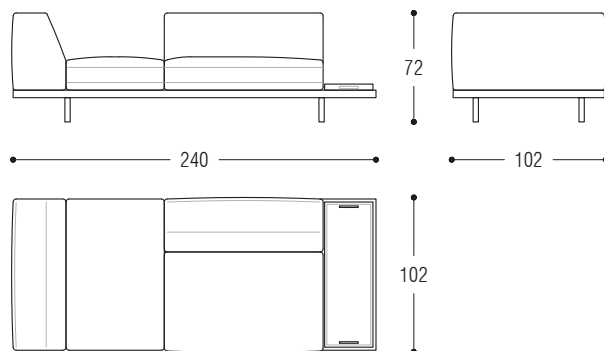

Atlas outdoor

Bench cm 240 for left tray (also available right) without headrests

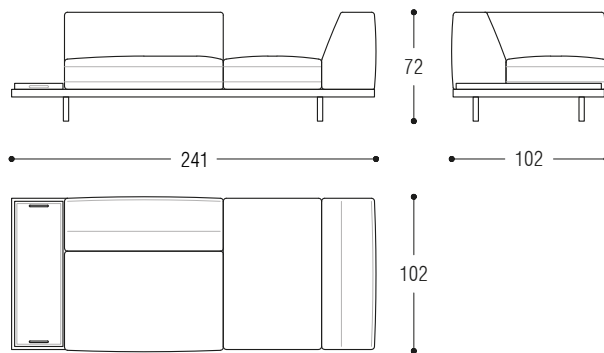

Sofa cm 180 with headrest

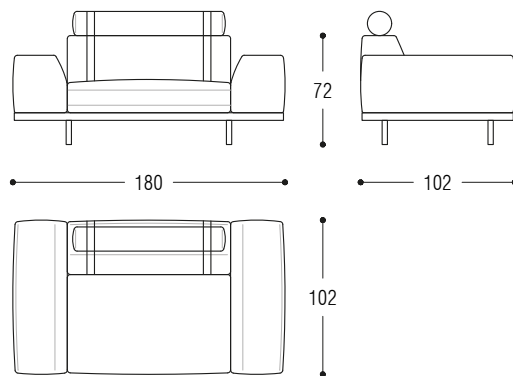

Sofa cm 240 with headrest

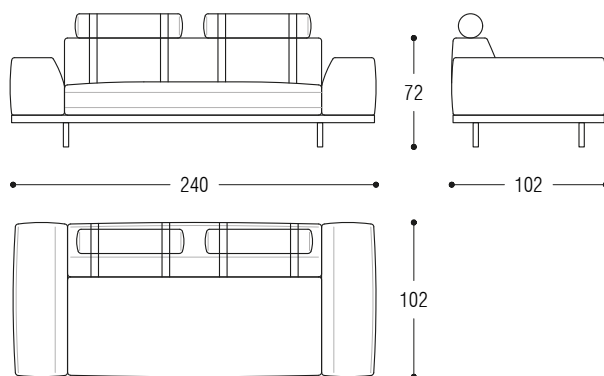

Atlas outdoor

Element cm 180 left (also available right) with headrest

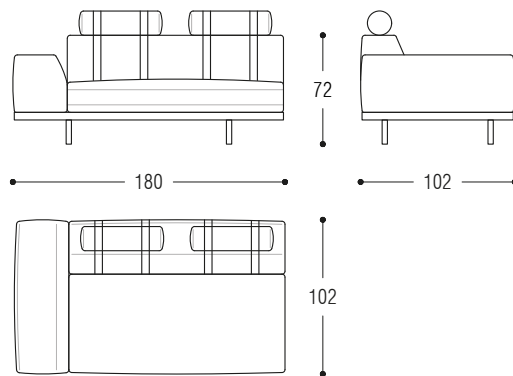

Element cm 180 right (also available left) with headrest

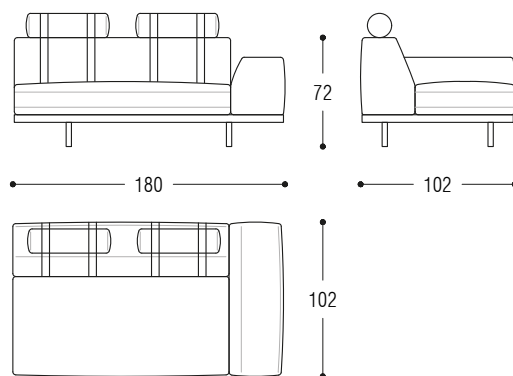

Element cm 240 left (also available right) with headrest

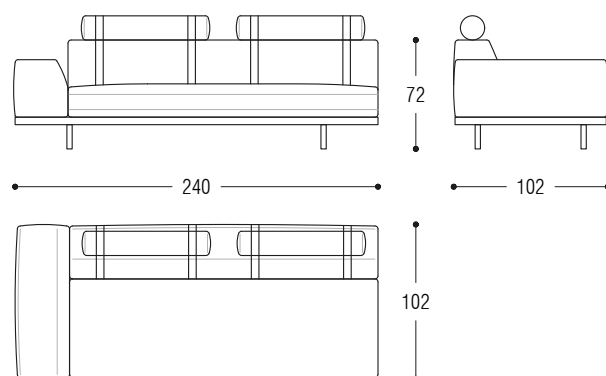

Atlas outdoor

Element cm 240 right (also available left) with headrest

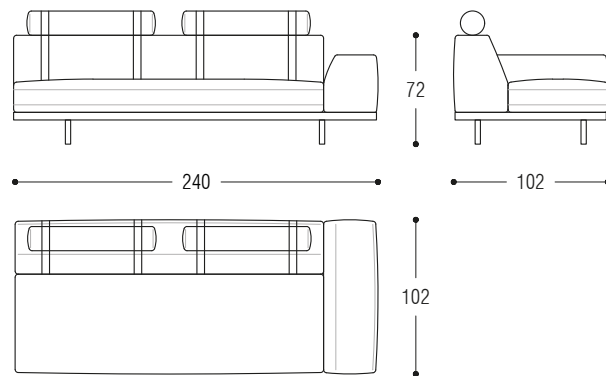

Endunit cm 180x100 with headrest

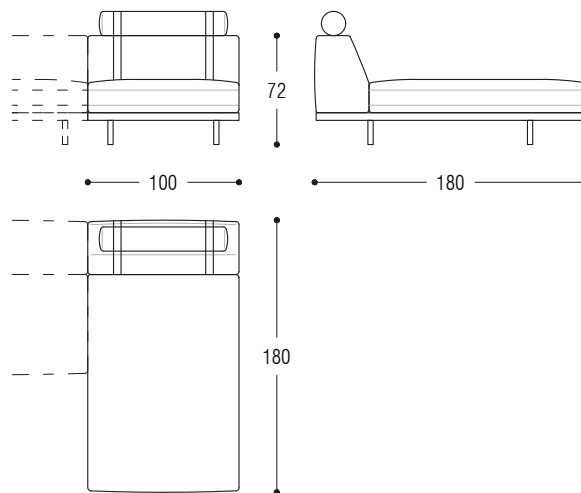

Sunbed cm 180x100 with headrest

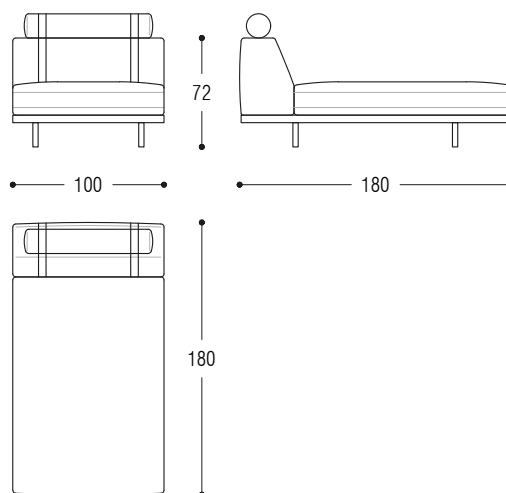

Atlas outdoor

Bench cm 240 for right tray (also available left) with headrests

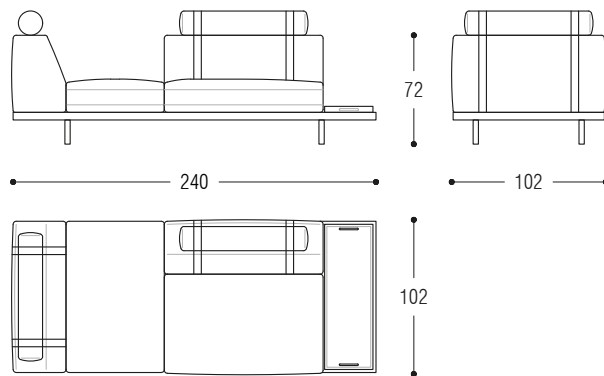

Bench cm 240 for left tray (also available right) with headrests

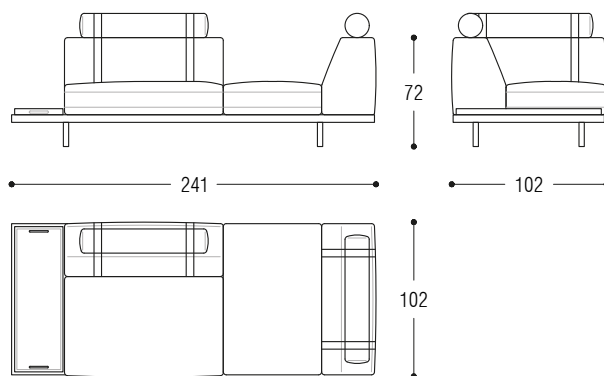

Armrest

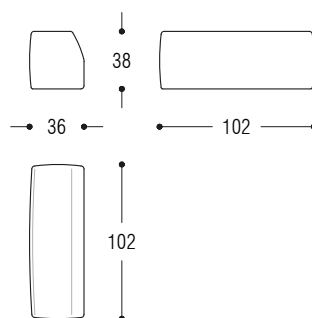

Atlas outdoor

Tray cm 96x32 in iroko wood

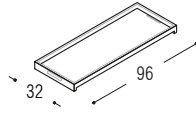

Atlas outdoor - important info

Sofas side elements and Bench - striped fabric orientation
Divani, Laterali e Panchetta - orientamento tessuti a righe
Sofas, Seitenelemente und Bank - Ausrichtung des gestreiften Stoffes

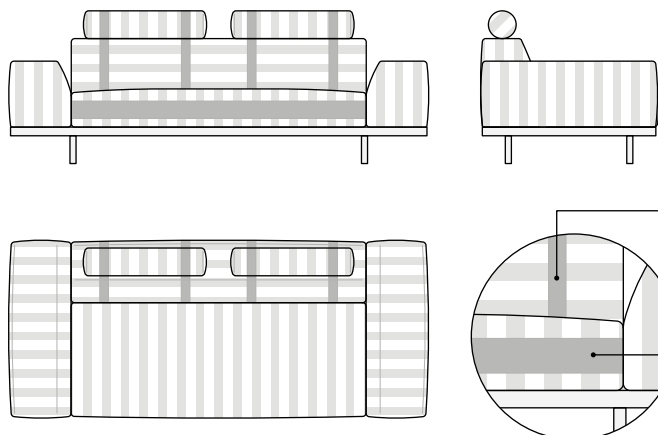

If a striped fabric is selected for sofas and lateral elements, the orientation of the pattern will always be as the one shown in the drawing.

Qualora venga selezionato un tessuto a righe per divani e laterali, l'orientamento del pattern corrisponderà sempre a quello mostrato nel disegno.

Wenn ein gestreifter Stoff für Sofas und seitliche Elemente ausgewählt wird, entspricht die Ausrichtung des Musters immer der in der Zeichnung dargestellten.

The material of the roller-holder bands is unique and cannot be customized.

Il materiale delle fasce porta-rotolo è unico e non può essere personalizzato.
Das Material der Rollenhalter-Bänder ist das einzige verfügbare und nicht anpassbar.

For products with striped fabric, it is necessary to select also a solid-color fabric from our collection, to be used for the seat cushion thickness band.

Per i prodotti con tessuto a righe è necessario selezionare anche un tessuto tinta unita della nostra collezione, da utilizzare per la fascia spessore del sedile.

Für Produkte mit gestreiftem Stoff muss zusätzlich ein Uni-Stoff aus unserer Kollektion ausgewählt werden, der für das Sitzkantenband verwendet wird.

Endunit - striped fabric orientation
Isola - orientamento tessuti a righe
Endgerät - Ausrichtung des gestreiften Stoffes

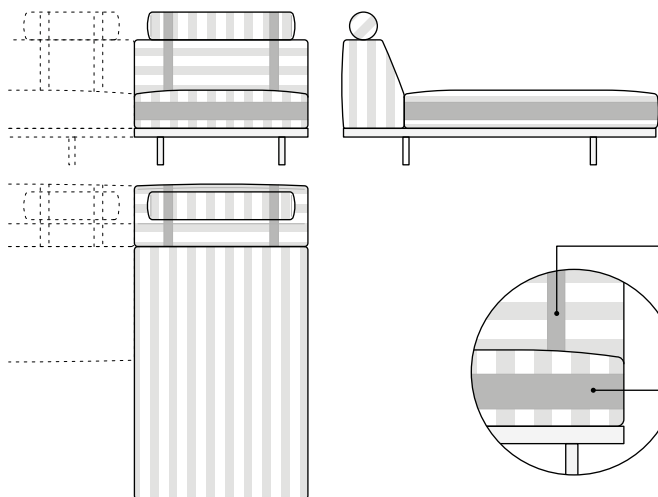

If a striped fabric is selected for the endunit, the orientation of the pattern will always be as the one shown in the drawing.

Qualora venga selezionato un tessuto a righe per l'isola, l'orientamento del pattern corrisponderà sempre a quello mostrato nel disegno.

Wenn ein gestreifter Stoff für Endgerät ausgewählt wird, entspricht die Ausrichtung des Musters immer der in der Zeichnung dargestellten.

The material of the roller-holder bands is unique and cannot be customized.

Il materiale delle fasce porta-rotolo è unico e non può essere personalizzato.
Das Material der Rollenhalter-Bänder ist das einzige verfügbare und nicht anpassbar.

For products with striped fabric, it is necessary to select also a solid-color fabric from our collection, to be used for the seat cushion thickness band.

Per i prodotti con tessuto a righe è necessario selezionare anche un tessuto tinta unita della nostra collezione, da utilizzare per la fascia spessore del sedile.

Für Produkte mit gestreiftem Stoff muss zusätzlich ein Uni-Stoff aus unserer Kollektion ausgewählt werden, der für das Sitzkantenband verwendet wird.

Sunbed - striped fabric orientation
Letino - orientamento tessuti a righe
Sonnenbank - Ausrichtung des gestreiften Stoffes

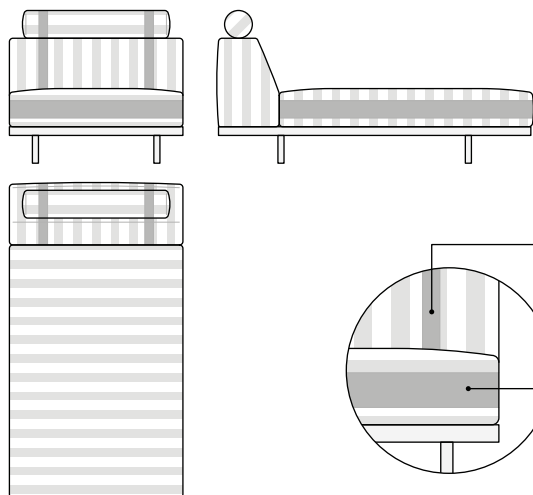

If a striped fabric is selected for the sunbed, the orientation of the pattern will always be as the one shown in the drawing.

Qualora venga selezionato un tessuto a righe per il lettino, l'orientamento del pattern corrisponderà sempre a quello mostrato nel disegno.

Wenn ein gestreifter Stoff für Sonnenbank ausgewählt wird, entspricht die Ausrichtung des Musters immer der in der Zeichnung dargestellten.

The material of the roller-holder bands is unique and cannot be customized.

Il materiale delle fasce porta-rotolo è unico e non può essere personalizzato.
Das Material der Rollenhalter-Bänder ist das einzige verfügbare und nicht anpassbar.

For products with striped fabric, it is necessary to select also a solid-color fabric from our collection, to be used for the seat cushion thickness band.

Per i prodotti con tessuto a righe è necessario selezionare anche un tessuto tinta unita della nostra collezione, da utilizzare per la fascia spessore del sedile.

Für Produkte mit gestreiftem Stoff muss zusätzlich ein Uni-Stoff aus unserer Kollektion ausgewählt werden, der für das Sitzkantenband verwendet wird.